

# SILGUARD™ BY INVERGE

U.S. Pat. No. 11230875 & D952904

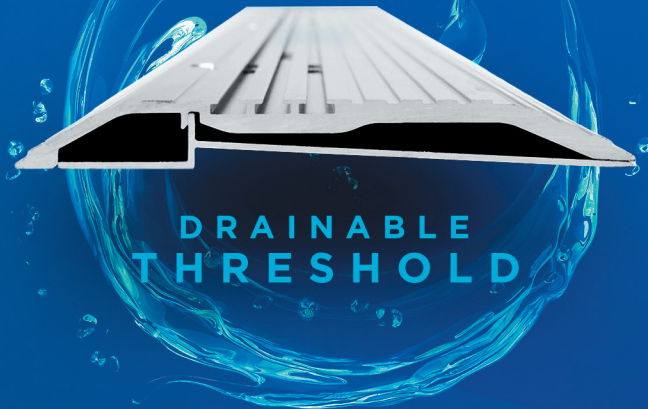

DRAINABLE  
THRESHOLD



**A REVOLUTIONARY NEW COMMERCIAL THRESHOLD** minimizing water intrusion inside buildings by draining water away from doors during rain or a standard doorway cleaning. The only ADA compliant drainable threshold for commercial doors.

#### PROBLEM:

Leaking commercial door thresholds faulty design, allowing water to come over threshold, causing slip and fall injuries, as well as mold and fungus due to bacteria growth.

#### SOLUTION:

# SILGUARD™ BY INVERGE

#### FEATURES & BENEFITS

- The patented design returns water back to the exterior at a minimum rate of 2 gal/min
- Made for doors with hinges or pivots
- Helps prevent slip and falls by minimizing water intrusion
- Helps prevent mold and bacteria growth on floors and walls
- Can replace existing thresholds with similar dimensions
- Does not require exposed caulking at sides that deteriorate with time
- Made to ADA standards
- Professional installations are fast



**INVERGE** - A leader in innovative solution-based products for the construction industry.

[www.InvergeIc.com](http://www.InvergeIc.com)

CALL TO ORDER | 800.610.3906

# SILGUARD™ BY INVERGE

U.S. Pat. No. 11230875 & D952904

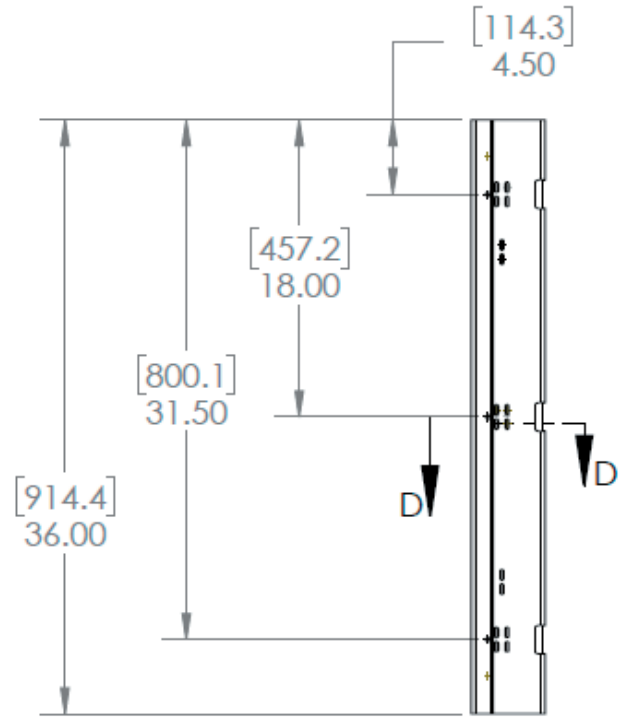
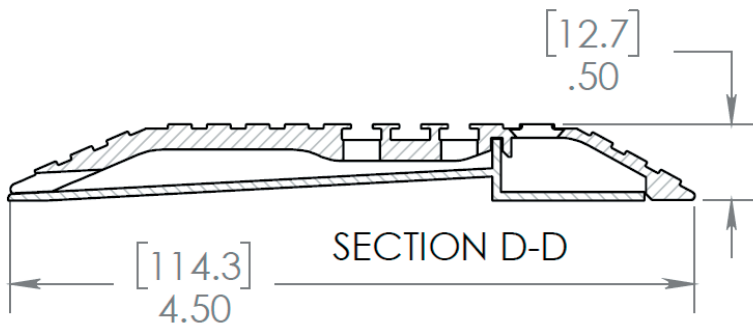

**MATERIAL:**

6063-T6 Anodized Aluminum

**FINISH:**

Clear and Dark bronze

**LENGTHS:**

36", 42", and 72" in stock. Quotes can be provided for custom sizes upon request.

**DEPTH:**

4.5" (114.3 mm)

**HEIGHT:**

.5" (12.7 mm)

**WEIGHT:**

1 lb. per 12"

**FLOW RATE:**

2 gallons per minute minimum

**AVAILABILITY:**

Ships from your local distributor

**TESTING:**

Testing completed to meet the requirements for the following:

ANSI/BHMA 156.21 - Comprehensive load test.

ANSI A117.1 - ADA Confirmation.

ANSI A137.1 - Static Coefficient of Friction test.

SilGuard is 100% aluminum and considered non-combustible per ASTM E-136 and NFPA 80, Section 6.4.9.

SilGuard will not derate any door assembly.

**INVERGE** - A leader in innovative solution-based products for the construction industry.

[www.Invergellc.com](http://www.Invergellc.com)

**CALL TO ORDER | 800.610.3906**