



DIVISION: 08 00 00—OPENINGS
Section: 08 71 00—Door Hardware

REPORT HOLDER:

INVERGE LLC

EVALUATION SUBJECT:

SILGUARD™ DRAINABLE THRESHOLD

1.0 EVALUATION SCOPE

Compliance with the following codes:

- 2021 *International Building Code*® (IBC)
- 2021 *International Residential Code*® (IRC)

Properties evaluated:

- Accessibility
- Drainable Features

2.0 USES

The SilGuard™ Drainable Threshold is a commercial door threshold used in exterior door applications. The threshold may be used where accessibility compliance in accordance with IBC Section 1010.1.6, Sections 302.3 and 402.4 of the 2017 ICC A117.1 as referenced in IBC Chapter 11 or Section R320 of the IRC is required. Additionally, the threshold is designed with drainable features to divert water to the exterior.

3.0 DESCRIPTION

3.1 General:

The SilGuard™ Drainable Threshold is an extruded member made from aluminum alloy 6063-T6. The threshold measures 4.5 inches (114 mm) wide by 0.5 inches (12.7 mm) tall and comes in 36, 42 and 72-inch-lengths (914, 1067 and 1829 mm). Custom lengths are also available. See Figure 1 for product description.

3.2 The SilGuard™ Drainable Threshold complies with the 1/2-inch (12.7 mm) threshold height requirements in accordance with IBC Sections 101.1.6 and 1102 and IRC Section R320.

3.3 The SilGuard™ Drainable Threshold complies with the 1/2-inch (12.7 mm) maximum size for floor opening requirements in accordance with Section R302.3 of 2017 ICC A117.1 as referenced in IBC Chapter 11.

3.4 The SilGuard™ Drainable Threshold complies with the threshold compressive load requirements of 1,000 lbs (4,448 N) for standard duty applications when tested in accordance with Section 4.1 of ANSI/BHMA A156.21-2019, American National Standard for Thresholds.

3.5 The SilGuard™ Drainable Threshold has the ability to drain water to the exterior that passes through the bottom of the door at a rate of 2.3 gallons per minute (8.7 Liters per minute).

3.6 The SilGuard™ Drainable Threshold complies as a noncombustible material when tested in accordance with ASTM E136.

4.0 INSTALLATION

The SilGuard™ Drainable Threshold must be installed on a concrete substrate using approved corrosion resistant anchors. Approved caulking shall be installed in accordance with manufacturer's recommendations. The bottom threshold piece and top threshold piece shall be placed together into the caulked area and secure with approved anchors.

5.0 CONDITIONS OF USE

The SilGuard™ Drainable Threshold described in this report complies with, or is a suitable alternative to what is specified in, those codes listed in Section 1.0 of this report, subject to the following conditions:

5.1 The SilGuard™ Drainable Threshold must be installed in accordance with this report and the published manufacturer's installation instructions and this report. Where a conflict exists between the manufacturer's published installation instructions and this report, this report governs.

6.0 EVIDENCE SUBMITTED

Data in accordance with the ICC-ES Acceptance Criteria for Drainable Threshold Used with Exterior Doors (AC533) dated June 2022.

7.0 IDENTIFICATION

7.1 The SilGuard Drainable Threshold must be identified by the name of the report holder (Inverge LLC), product type and number, and the evaluation report number (ICC-ES ESR-5048).

7.2 The report holder's contact information is the following:

INVERGE LLC
9631 ROSEBAY STREET
ANAHEIM, CALIFORNIA 92804
(800) 610-3906
www.invergellc.com
dan@invergellc.com



SilGuard 36"

Commercial, Drainable Threshold



ADA-Compliant

Project:	
Submitted by:	
Date:	
Notes:	

Product Details:

- Anodized 6063-T6 Aluminum
- 4.5" Wide X .5" Tall
- .17" Cover Thickness
- 1.0 [lb/ft] Assembled
- Clear Finish (P/N 36CL001)
- Dark Bronze (P/N 36DB001)



Contact Us:

www.InvergeLLC.com
 Info@InvergeLLC.com
 800 610-3906

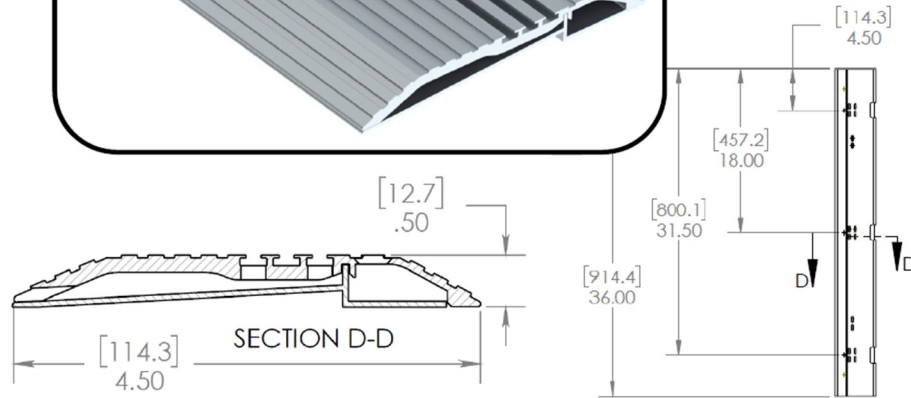

© Inverge LLC 2022

FIGURE 1—SILGUARD DRAINABLE THRESHOLD